

DTA

D-TA SYSTEMS INC.

SENSOR INTERFACE & PROCESSING COMPANY

D-TA DESIGN GROUP

CUSTOM SOLUTIONS FOR RAPID DEPLOYMENT



D-TA Design Group

D-TA Design Group is part of D-TA System Inc. The group offers custom design, development and manufacturing services primarily in the sensor processing area. Leveraging the tremendous expertise and facilities of D-TA Systems, D-TA 's Design Group spans from RF systems, Digital & Mixed-Signal Boards, FPGA Cores, and Software.

SENSOR PROCESSORS THAT DRASTICALLY REDUCE DEPLOYMENT TIME AND COSTS

DTA- Expertise

D-TA Systems Inc. occupy over 10,000 sq. ft of office and Laboratory space that is well equipped with state-of-the art test equipment, design tools and prototype production facility.

D-TA's team of highly skilled Engineers includes 3 PhDs and others with Master's & Bachelor's Degrees.

D-TA's extensive design and development capabilities include:

- RF System Development
- Mixed-Signal Board & System Development
- FPGA Board and Core Development
- Signal Processing Algorithm Development
- Embedded Software Development



Top notch experts in high-end sensor interface and processing who delivered:

- ✓ World's FIRST Digital Radio
- ✓ World's FIRST COTS Sonar
- ✓ ANSI Standard FPDP Interface
- ✓ World's FIRST Network Attached Sub-Systems
- ✓ NOW World's FIRST 10GbE Network Attached Sub-Systems

Customization: Custom tailor Standard Products to meet requirements

- ADC and /or DAC upgrade
- Channel count and bandwidth
- Larger FPGA and Data Memory
- FPGA core development
- Software development service
- Fixed RF band(s) & different bandwidth
- Smart Recording based on predefined signal activities for SIGINT, ELINT and COMINT
- Increased or reduced data storage
- Repackaging into small enclosure
- Ruggedization

Low-Cost Customization of Standard products

DTA-2210



DTA-2210
[1U X 19" X 10.5"]

- Low-Cost & Compact System for SIGINT, TDOA, Radar, Tactical Receiver, Sonobuoy Receiver, Spectral Monitoring, RF Test, etc.
- 16-Bit, 160 MSPS ADC & 500 MSPS Dual DAC
- SX50T or SX95T Virtex 5 FPGA
- Internal / External Ref. Clock
- Multiple DTA-2210 Can be Synchronized
- DTA-3200-01-01 (20 MHz – 6 GHz) Tunable RF Front-End
- DTA-5000 Record / Playback System

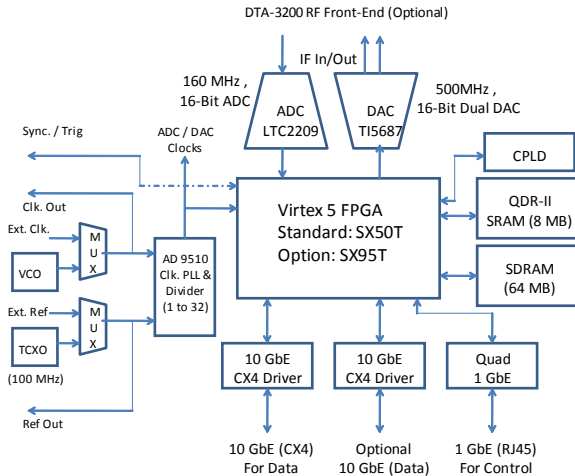

Customization may include ADC and /or DAC upgrade, larger FPGA and Data Memory, and FPGA core development. Software development service, repackaging and ruggedization options are also available.

Low-Cost Customization of Standard products

DTA-2300

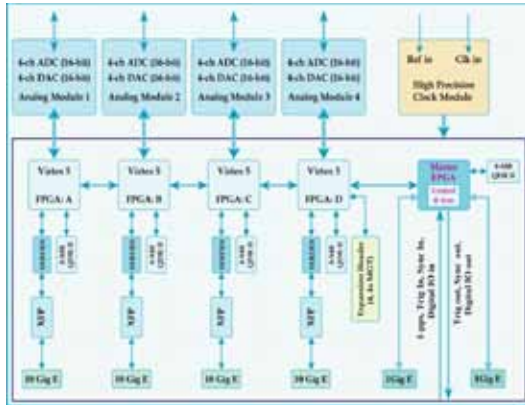

DTA-2300 Multi-Antenna Software Radio Platform (1U X 24") for synchronized Receive & Transmit operation for up to 16 channels (antennas). DTA-2300 includes up to four 10 Gigabit optical networks for data and two 1 Gigabit networks for control.

Customization may include ADC and /or DAC upgrade, larger FPGAs and Data Memory, and FPGA core development for merging/splitting network data and or/signal processing. Variety of daughter cards for added functionality, repackaging, ruggedization and software development service are also available.

Low-Cost Customization of Standard products

DTA-3200

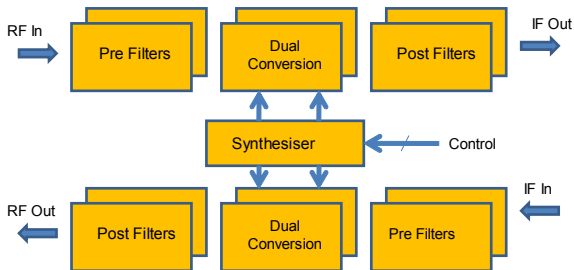

Synchronized Multi-Antenna RF/IF Transceiver (Tunable From 20 MHz to 6 GHz)



DTA-3200 Tunable RF/IF Transceiver that is available from 1 to 16 configuration. The maximum BW is 40 MHz and the frequency coverage is from 20 MHz to 6 GHz.

Customization may include fixed RF band(s); different bandwidth, IF and frequency band; and repackaging.

Low-Cost Customization of Standard products

DTA-5000

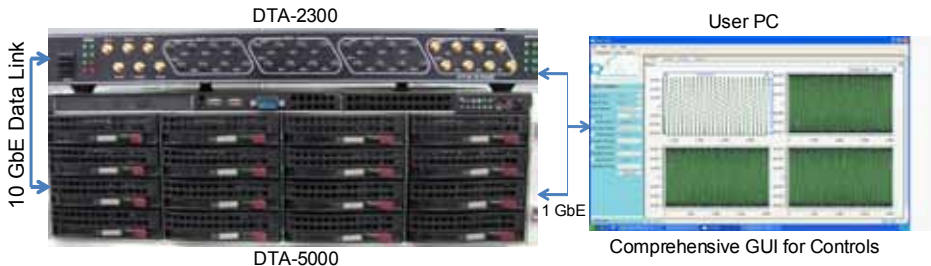

[Figure shows a 10G/R1 system that includes a DTA-2300 & a DTA-5000]

- 3U form factor with 4.8 TB or 9.6 TB storage capacity
- Packaged with DTA-2210/2300 for Radio Signals (10G/R1, 10G/R2, 10G/R4) and DTA-4100 for Acoustic Signals (10G/S1, 10G/S2, 10G/S4)
- Phase Coherent (Synchronized) Recording & Playback of Multiple Radio or Acoustic Signals. The 10G Series includes one DTA-5000 per 10 Gigabit Fiber.
- Multiple DTA-5000s Operate Synchronously
- Complete System Command and control from DTA-5000 GUI
- Sustained data rate of up to 2.4 Gbytes/s
- Time Series and FFT Snapshot Display During Recording & Playback for Data Quality Check

The DTA-5000 is based on a flexible software architecture. Almost any processing functions can be added to the system. Signal processing functionality can be implemented in software inside the recorder system as it includes multiple General-Purpose Processing (GPP) cores. Smart Recording based on predefined signal activities for SIGINT, ELINT and other applications to reduce the amount of data storage.

RF Design & Component Fabrication Capability



In house filter design capability includes:

- Lumped element and distributed element design
- Quick turn module development for prototyping
- Extensive RF testing capability for filter tuning

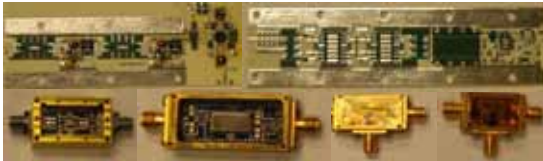

D-TA Design Services RF development expertise also includes quick turn module development for prototyping for:

- Amplifiers, Mixers, band specific amplification, etc. are quickly verified and optimized
- Verification of actual performance with cascade analysis



In house chassis and enclosure design capabilities include thermal, shielding and isolation design

Custom Mixed-Signal & FPGA Products

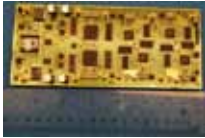

Four 160 MHz , 16-Bit ADCs &
500 MHz , 16-Bit DAC Board



22 Layer DSP & 10 Gigabit
Network Interface Board

D-TA Engineers have extensive experiences in the design and development of high-precision analog, high-speed digital and FPGA based signal processor and network interface. Past designs include:

- ADC & DACs with 16-Bit precision and over 100 MHz sample rates
- 24- Bit ADCs with sample rates over 2 MHz for Acoustic applications
- FPGA Boards for Ultra High-Speed DSP and 10 Gigabit Network Interfaces
- Bus-Based COTS boards
- Conduction-cooled systems
- Optical & Copper based 10 GbE network interfaces

Software Development Support & Training for Multi-Core Server Class Computers

DATA SDK

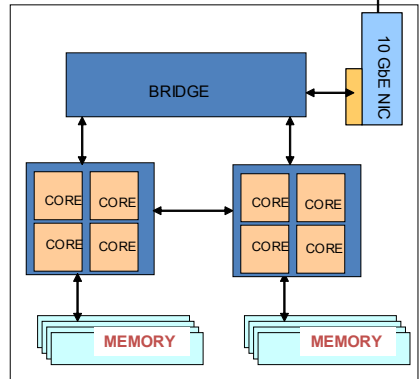
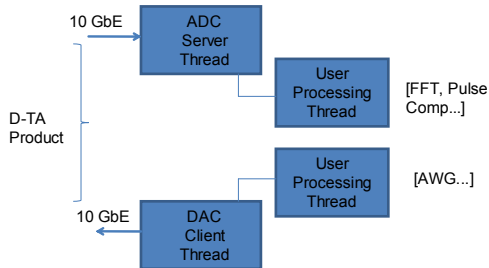

D-TA 's Full Source code Base Software Development Kit (SDK) includes Control API for controlling the DTA products and Data API for processing. Real Time Applications (DSP Codes) can be developed as add-on modules to the Base SDK.

D-TA offers Custom Multi-processor and multi-threaded Application Development based on user requirement and also hands on training either at factory or on-site

Major Custom Design Wins

4-Channel (Antenna) Synchronized & Tunable RF to IF Transceiver for WiMAX MIMO Applications in the Frequency Band (2.1 -2.3 GHz) and (5.0 -5.8 GHz).



Highly Compact, Low-Power, Conduction-Cooled Intelligent Network Receiver for SIGINT and Distributed TDOA Geo-location.



Conduction-Cooled Virtex 6 (Xilinx FPGA) based Video Processing System for Military Vehicles. The system is being designed for major volume production.



Why D-TA Systems

- Extensive design, development capabilities and program management capabilities
- Proven Standard and Custom products
- State of the art technology: Tunable RF, Precision IF, FPGA, Multi-core processing, 10 Gigabit Network
- Applications specific software development
- Global customer base with major wins from Prime Contractors and Defense Labs
- Local technical support and sales representatives



United States: D-TA Systems Corporation

900 Bestgate Rd, Suite 102

Annapolis, MD 21401

Toll Free: 1 (877) 382-3222

sales@d-ta.com

International: D-TA Systems Inc.

2500 Lancaster Road

Ottawa, ON, K1B 4S5 Canada

Phone: 1 (613) 745-8713 **Fax:** 1 (613) 745-1429